

DIGITAL HANDRAIL SCALES WITH HEIGHT ROD

MODELS 6855MHR / 6856MHR



Model
6856MHR

- Weigh, measure, and BMI
- High 1,000 lb/450 kg and 600 lb/270 kg capacities available
- Stable handrail provides support during weighing
- Extra-wide and low-profile platforms
- 8 different models to choose from



Model
6855MHR

HIGH-CAPACITY WAIST-HIGH STAND-ON SCALES WITH HEIGHT RODS

- Ideal for obese and unsteady patients
- Integral wheels for transport
- Height rod measures up to 84 in/212 cm
- Body Mass Index
- Low-profile and wide-base platform
- Printer connectivity
- OIML Class III models available



Engineered and manufactured for obese and unsteady patients, DETECTO's 6855MHR and 6856MHR scales feature a balanced design that can be easily tipped back for transport on its rubber wheels. The low-profile platform, wide base, convenient handrails, and slip-resistant mat make them ideal for bariatric patients and aid user assurance while weighing.

The Lock/Release key can hold and release the patient weight, allowing the medical professional time to attend to the patient first and then record their measurements. The ability to print or save weight data is a real time-saving device for hospitals, clinics, doctor's offices, long-term care centers, and other medical facilities.



Wi-Fi/Bluetooth wireless connectivity available
Order models -C.



*The Name Brand Preferred
by Clinical Professionals
Around the World*



STABLE HANDRAIL FOR PATIENT ASSURANCE

Wraparound tubular stainless steel handrails with padded foam handgrips for patient stability and safety.



ROOMY PLATFORM WITH SLIP-RESISTANT MAT

The model 6856MHR's platform (shown) is 24 in W x 24 in D / 61 cm W x 61 cm D and the model 6855's platform is 18 in W x 14 in D / 46 cm W x 36 cm D.



EASY-TO-USE KEYPAD

The scale's indicator is easy to use with only 5 basic keys, plus directional arrows for factoring BMI.

LOADED WITH BARIATRIC WEIGHING FEATURES

Multi-Functional Handrail Scale with Wireless Transmission Capabilities



HIGH CAPACITY AND BMI FUNCTION

Choose from 600 lb/270 kg (685MHR) or 1,000 lb/450 kg capacity models (6856MHR)



QUALITY CONSTRUCTION

The scale's handrails are manufactured in beautiful stainless steel and almost all other components are powder painted mild steel for long-lasting durable construction.



HEIGHT ROD INCLUDED

The scale's height rod measures 24 in to 84 in x 0.1 in / 60 cm to 212 cm x 0.1 cm. The height rod accounts for the scale's platform height that it is mounted above.



Wi-Fi/Bluetooth wireless comes standard with -C models for EMR/EHR connectivity

Healthcare for disabled, obese, and elderly patients requires products which meet specific capabilities. DETECTO's 6855MHR and 6856MHR digital scales cover a wide range of patient type weighing and measurement needs in hospitals, rehabilitation centers, nursing homes, and dialysis centers.

The scale's sturdy stainless steel handrails allow users the advantage of a firm brace to hold onto while weighing and measurement takes place. This makes the life of the nursing staff easier during the process. Since the handrail is built into the weighing platform, you are assured that all measurements are highly accurate when the patient supports themselves on it.

With the BMI function capability, you can determine the ratio of the weight to height using the indicator's arrow keys, which provides objective data on the nutritional condition of the patient.



INTEGRAL WHEELS

Dual integral wheels allow you to tip the scale back and roll it wherever needed for transport within your facility.



BATTERY POWER

The scale may be powered by 6 AA batteries (not included) allowing you to use it anywhere.

DIGITAL HANDRAIL SCALES WITH HEIGHT ROD



Model	6855MHR	6855MHR-AC	6855MHR-C	6855MHR-C-AC	6856MHR	6856MHR-AC	6856MHR-C	6856MHR-C-AC
Capacity	600 lb x .02 lb or 270 kg x 0.1 kg (selectable upon initialization)				1,000 lb x .02 lb or 450 kg x 0.1 kg (selectable upon initialization)			
Platform Size	18 in W x 14 in D / 46 cm W x 36 cm D				24 in W x 24 in D / 61 cm W x 61 cm D			
Height Rod	24 in to 84 in x 0.1 in / 60 cm to 212 cm							
Display	Six digits, seven segments, 0.7 inches (17.8 mm) high LCD							
Keypad	Membrane type with 5 keys: On/Off, Lock/Release, Units, Zero, BMI/Enter, and 4 directional arrows							
Power	6 AA size Alkaline, Ni-Cad, or NiMH batteries (not included) OR 100-240 VAC 50/60Hz 12 VDC 1A wall plug-in UL/CSA listed AC power adapter (only included with -AC models): DETECTO part number 6800-1045 AC adapter.							
AC Adapter Included		●		●		●		●
Wi-Fi/Bluetooth Connectivity			●	●		●		●
Construction	Stainless steel handrails. Painted mild steel platform, column, and indicator.							
Outer Dimensions (with height rod folded down):	29.3 in W x 17.5 in D x 49.8 in H / 74.4 cm W x 44.5 cm D x 126.5 cm H				35.3 in W x 27.5 in D x 49.8 in H / 89.7 cm W x 69.9 cm D x 126.5 cm H			
Shipping Weight	70 lb / 32 kg				85 lb / 39 kg			
Country of Origin	USA				USA			
UPC Code	809161331103	809161331202	809161331301	809161331400	809161331509	809161331608	809161331707	809161331806



OIML Class III
Compliant models
are also available
by adding a
-KGEU suffix when
ordering. Capacity:
300 kg x 0.1 kg

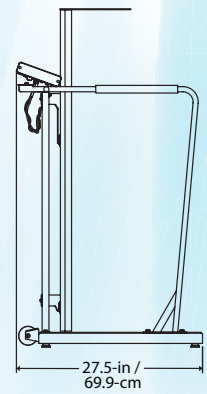
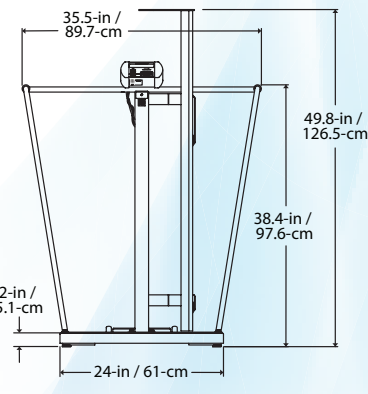
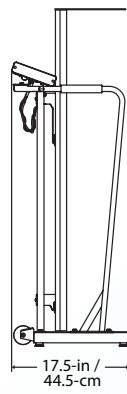
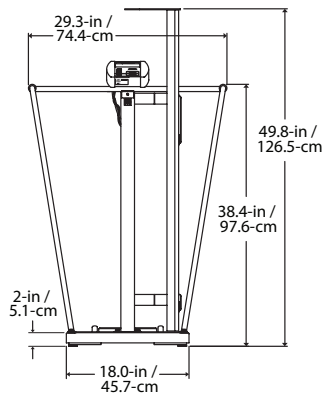

Detecto Scale reserves the right to improve, enhance, or modify features and specifications without prior notice.

SOLD BY:

 **DETECTO**
www.Detecto.com

102 E. Daugherty, Webb City, MO 64870 USA
Ph: 417-673-4631 or 1-800-641-2008 Fax: 417-673-2153
www.Detecto.com