

ZONE		LTR.		DESCRIPTION		DATE	ECN	BY	CKD	APVD
-		B		REDRAWN FOR CATALOG; CORRECTED DIM D		05/22/15	2015-36	RLU	JSP	AA

PERFORMANCE SPECIFICATIONS:

1. CAPACITIES: 5K & 10K. (LB)
2. RATED OUTPUT: 4.00 mV/V $\pm 0.25\%$.
3. SAFE OVERLOAD: 150% FS.
4. EXCITATION VOLTAGE: 10V AC/DC (15V MAX).
5. INPUT RESISTANCE: 380 $\pm 10\Omega$.
6. OUTPUT RESISTANCE: 350 $\pm 5\Omega$.
7. ZERO BALANCE: $\pm 1.00\%$ FS.
8. SEAL TYPE: ENVIRONMENTALLY SEALED IP67.
9. NON-LINEARITY: $\pm 0.05\%$ FS.
10. HYSTERESIS: $\pm 0.03\%$ FS.
11. REPEATABILITY: $\pm 0.01\%$ FS.
12. CREEP: $\pm 0.03\%$ FS IN 30 MINUTES.
13. COMPENSATED TEMPERATURE RANGE: -10°C TO $+40^{\circ}\text{C}$.
14. TEMPERATURE EFFECTON ZERO: $\pm 0.0027\%$ FS/ $^{\circ}\text{C}$.
15. TEMPERATURE EFFECT ON OUTPUT: $\pm 0.0015\%$ FS/ $^{\circ}\text{C}$.
16. INSULATION RESISTANCE: 5000 MEGOHMS.
17. LOAD CELL CABLE: 4-24AWG, $\varnothing 5.6\text{MM}$, PVC, 20FT.
18. LOAD CELL WIRING:
GRN (+EXC)
BLK (-EXC)
WHT (+SIG)
RED (-SIG)
YELLOW: SHIELD
19. FM APPROVED.

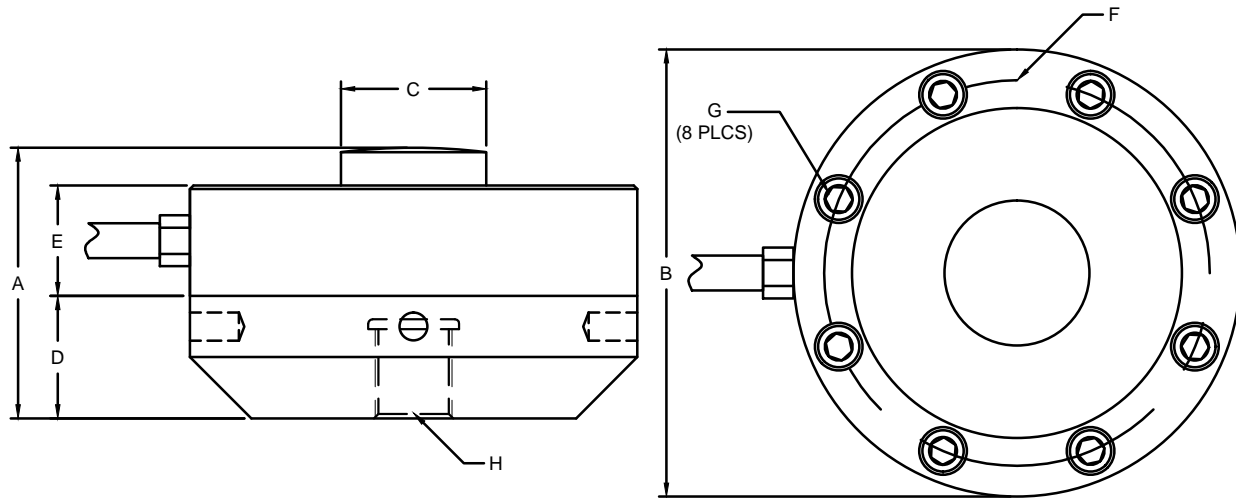

TOP VIEW

RATED CAPACITY	DIMENSIONS							
	A	B	C	D	E	F	G	H
5K - 10K	2.50	4.13	1.34	1.13	1.02	3.56	M6	5/8-18x0.88

DO NOT ALTER WITHOUT AGENCY NOTIFICATION

COTI GLOBAL SENSORS, INC.

CG - 1211
CANISTER LOAD CELL

APPROVALS		DATE	SCALE	SIZE	PART/DRAWING NO.	REV.
DRAWN:	RLU	05/22/15	NONE	B	DOD-CG-1211	B
CHECKED:	AA	05/22/15				
ENGINEER:	JSP	05/22/15				
APPROVED:	AA	05/22/15				
MATERIAL:	STAINLESS STEEL					
FINISH:	PASSIVATED					
MODEL CG-1211			SHEET 1 OF 1			

THIS DOCUMENT CONTAINS PROPRIETARY INFORMATION AND SUCH INFORMATION MAY NOT BE REPRODUCED OR DISCLOSED FOR ANY PURPOSE OR USED TO PRODUCE THE ARTICLE OR SUBJECT WITHOUT WRITTEN PERMISSION FROM COTI GLOBAL SENSORS, INC.

TOLERANCES UNLESS OTHERWISE SPECIFIED
 .XX = $\pm 0.02"$
 .XXX = $\pm 0.005"$
 .XXXX = $\pm 0.0002"$
 FRACTIONS: $\pm 1/16"$
 ANGLES: DEC: ± 15