

ZONE		LTR.	DESCRIPTION	DATE	ECN	BY	CKD	APVD
-	C		REDRAWN FOR LABELING CONSISTENCY	5/26/15	2016-34	RLU	JSP	AA

**PERFORMANCE SPECIFICATIONS:**

- CAPACITIES: 500LB, 750LB, 1K, 2K, 3K, 5K, 10K, 20K, 25K, 30K, 50K, 100K. (LB).
- RATED OUTPUT: 3.00mV/V ±0.25%.
- SAFE OVERLOAD: 150% FS.
- EXCITATION VOLTAGE: 10V AC/DC (15V MAX).
- INPUT RESISTANCE: 380 ±10Ω.
- OUTPUT RESISTANCE: 350 ±5Ω.
- ZERO BALANCE: ±1.00% FS.
- SEAL TYPE: HERMETICALLY SEALED IP67.
- NON-LINEARITY: ±0.05% FS.
- HYSTERESIS: ±0.03% FS.
- REPEATABILITY: ±0.01% FS.
- CREEP: ±0.03% FS IN 30 MINUTES.
- COMPENSATED TEMPERATURE RANGE: -10°C TO +40°C.
- TEMPERATURE EFFECT ON ZERO: ±0.0027% FS/°C.
- TEMPERATURE EFFECT ON OUTPUT: ±0.0015% FS/°C.
- INSULATION RESISTANCE: 5000 MEGOHMS.
- LOAD CELL CABLE: 4-24AWG, Ø5.6MM, PVC, 50FT.
- LOAD CELL WIRING:
 

GRN (+EXC)	GRN (+EXC)
BLK (-EXC)	BLK (-EXC)
WHT (+SIG)	RED (+SIG)
RED (-SIG)	WHT (-SIG)
YELLOW: SHIELD	YELLOW: SHIELD
COMPRESSION + SIGNAL.	TENSION + SIGNAL
- FM APPROVED.

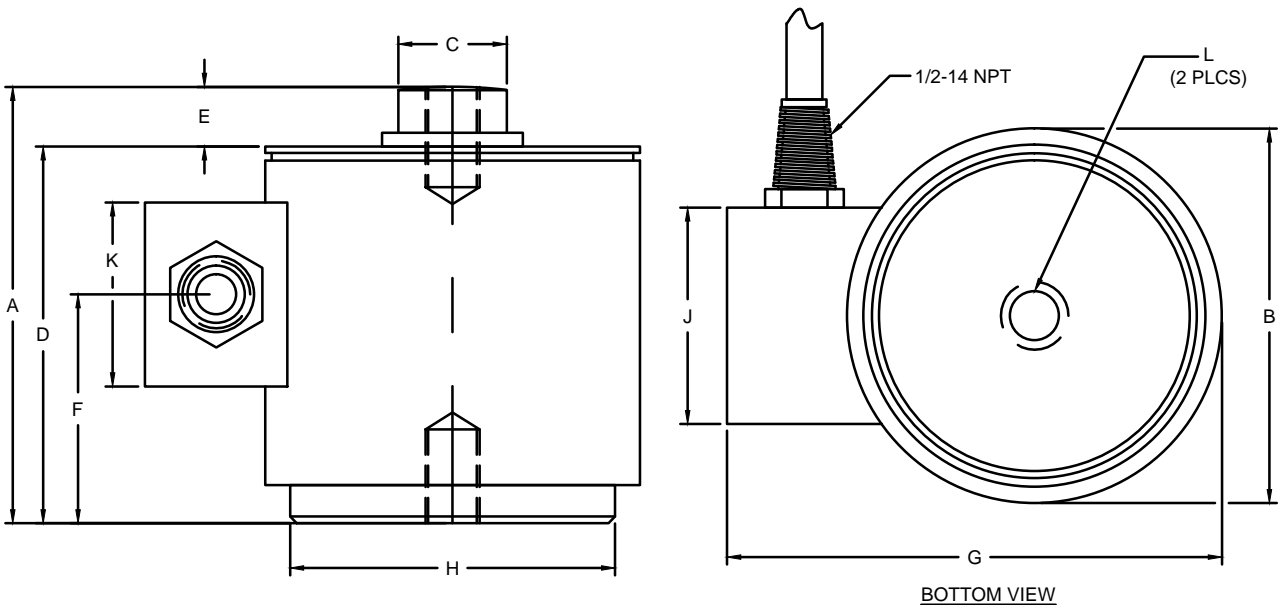

RATED CAPACITY	DIMENSIONS										
	A	B	C	D	E	F	G	H	J	K	L
500LB - 3K	4.56	3.50	0.75	4.27	0.49	2.32	4.61	2.99	1.57	1.57	1/2-20 x 0.56 DEEP
5K - 10K	5.94	3.50	1.35	5.41	0.53	2.95	4.54	2.99	1.97	1.97	1-14 x 1.25 DEEP
20K - 30K	8.50	5.00	2.50	7.81	0.69	4.19	6.04	4.49	1.97	1.97	1-1/2-12 x 2.00 DEEP
50K - 100K	11.44	6.50	3.00	10.75	0.76	5.62	7.46	5.79	1.97	1.97	2-12 x 2.62 DEEP

**DO NOT ALTER WITHOUT AGENCY NOTIFICATION**

COTI GLOBAL SENSORS, INC.

**CG - 31  
CANISTER LOAD CELL**

APPROVALS		DATE
DRAWN: RLU		05/26/15
CHECKED: AA		05/26/15
ENGINEER: JSP		05/26/15
APPROVED: AA		05/26/15
MATERIAL: STAINLESS STEEL		
FINISH: PASSIVATED		

THIS DOCUMENT CONTAINS PROPRIETARY INFORMATION AND SUCH INFORMATION MAY NOT BE REPRODUCED OR DISCLOSED FOR ANY PURPOSE OR USED TO PRODUCE THE ARTICLE OR SUBJECT WITHOUT WRITTEN PERMISSION FROM COTI GLOBAL SENSORS, INC.

TOLERANCES UNLESS OTHERWISE SPECIFIED  
 .XX = ±0.02"  
 .XXX = ±0.005"  
 .XXXX = ±0.0002"  
 FRACTIONS: ±1/16"  
 ANGLES: DEC: ±1/8"

SCALE	SIZE	PART/DRAWING NO.	REV.
NONE	B	DOD-CG-31	C