

REVISIONS							
ZONE	LTR.	DESCRIPTION	DATE	ECN	BY	CKD	APVD
-	F	ADDED NEW FT745 & 745A	05/23/19	2019-33	TB	AA	AA
-	G	UPDATED LOAD BUTTON DIMENSIONS	09/12/19	2019-38	TB	AA	AA

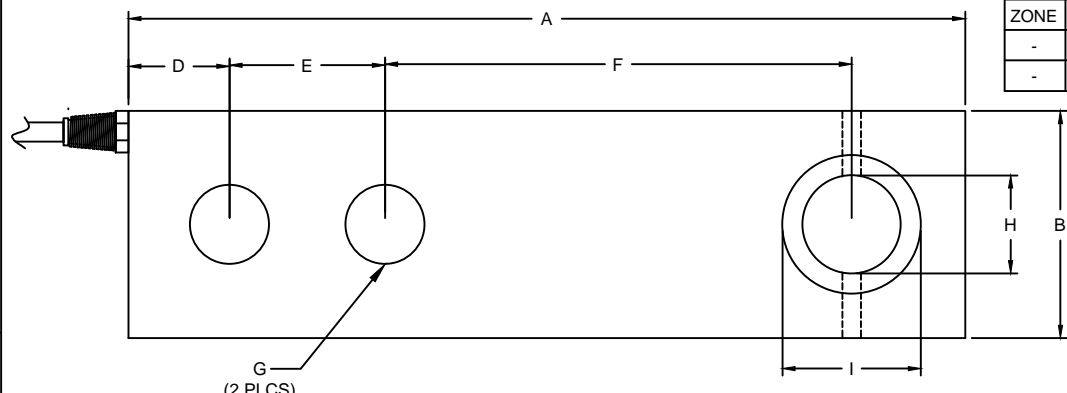

CG-745 TOP VIEW

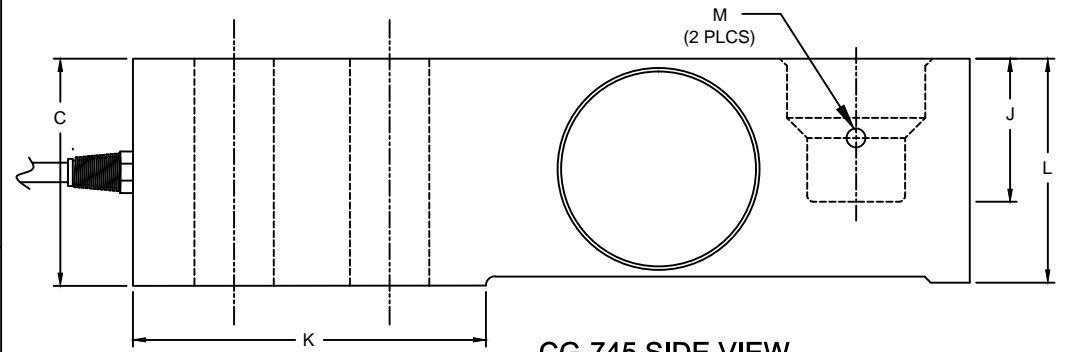

CG-745 SIDE VIEW

- PERFORMANCE SPECIFICATIONS:**
1. CAPACITIES: 500LB, 1K, 1.25K, 2.5K, 4K, 5K, 10K
 2. RATED OUTPUT: 2.00 mV/V ±0.5%.
 3. SAFE OVERLOAD: 150% FS.
 4. EXCITATION VOLTAGE: 10V AC/DC (20V MAX)
 5. INPUT RESISTANCE: 385 ±10Ω.
 6. OUTPUT RESISTANCE: 350 ±3Ω.
 7. ZERO BALANCE: ±1.00% FS.
 8. SEAL TYPE: ENVIRONMENTALLY SEALED.
 9. NON-LINEARITY: ±0.03% FS.
 10. HYSTERESIS: ±0.02% FS.
 11. REPEATABILITY: ±0.02% FS.
 12. CREEP: ±0.03% FS IN 30 MINUTES.
 13. COMPENSATED TEMPERATURE RANGE: -10°C TO +40°C.
 14. TEMPERATURE EFFECT ON ZERO: ±0.002%FS/C°.
 15. TEMPERATURE EFFECT ON OUTPUT: ±0.002%FS/C°.
 16. INSULATION RESISTANCE: 5000 MEGOHMS AT 50VDC.
 17. LOAD CELL CABLE: 4-24AWG, ∅5.6MM, OD, 30FT.
 18. LOAD CELL WIRING:

- GRN (+EXC)
- BLK (-EXC)
- WHT (+SIG)
- RED (-SIG)
- YELLOW (SHIELD)

19. FM APPROVED.

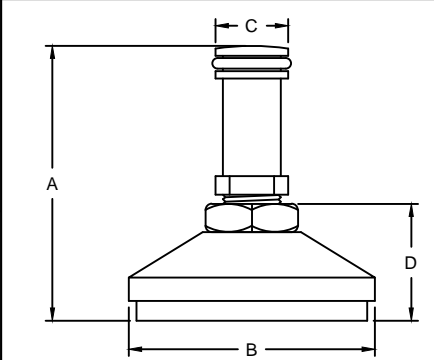

STOCK FT745, FT745A

RATED CAPACITY	DIMENSIONS			
	A	B	C	D
FT745	2.14 - 2.30	2.00	0.59	0.95
FT745A	2.76 - 2.92	2.75	0.85	1.52

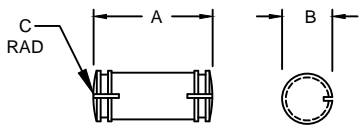

STOCK #655, #655A, #662

RATED CAPACITY	DIMENSIONS		
	A	B	C
#655	1.50	0.59	2.00
#655A	1.25	0.59	2.00
#662	1.73	0.85	2.00

RATED CAPACITY	DIMENSIONS												
	A	B	C	D	E	F	G	H	I	J	K	L	M
500LB-4K	5.25	1.21	1.19	0.63	1.00	3.00	0.51	0.63	0.89	0.69	2.27	1.18	0.12
5K	5.38	1.46	1.46	0.65	1.00	3.00	0.51	0.63	0.89	0.92	2.27	1.44	0.12
10K	6.75	1.69	1.69	0.75	1.50	3.75	0.78	0.89	1.38	1.07	2.91	1.67	0.12



THIS DRAWING USES THIRD ANGLE PROJECTION

THIS DRAWING CONTAINS PROPRIETARY INFORMATION AND SUCH INFORMATION MAY NOT BE REPRODUCED OR DISCLOSED FOR ANY PURPOSE OR USED TO PRODUCE THE ARTICLE OR SUBJECT WITHOUT WRITTEN PERMISSION FROM COTI GLOBAL SENSORS, INC.

TOLERANCES UNLESS OTHERWISE SPECIFIED:
 .XX"=±0.02"
 .XXX"=±0.005"
 .XXXX"=±0.0002"
 FRACTIONS ±1/16"
 ANGLES DEG. ±1/8"

APPROVALS	DATE
DRAWN: TB	05/23/19
CHECKED: AA	05/23/19
ENGINEER: TB	05/23/19
APPROVED: AA	05/23/19

MATERIAL: STAINLESS STEEL

DO NOT ALTER WITHOUT AGENCY NOTIFICATION

Coti Global Sensors
MANUFACTURING

Weighing Products Worldwide

Outline Dimensions
CG-745

SCALE	SIZE	PART/DRAWING NO.	REV.
NONE	B	DOD-CG-745	F

MODEL #CG-745 SHEET 1 OF 1