

REVISIONS							
ZONE	LTR.	DESCRIPTION	DATE	ECN	BY	CKD	APVD
-	-	INITIAL RELEASE	09/16/16	-	TB	AB	AA

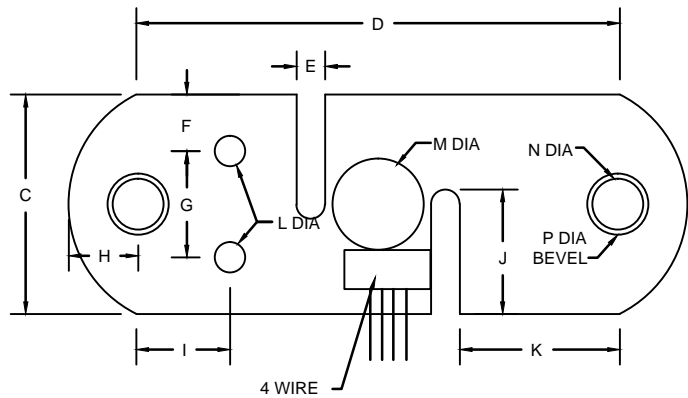
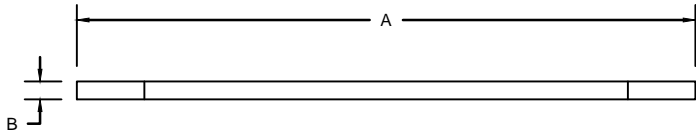

PERFORMANCE SPECIFICATIONS:

- CAPACITIES: 300kg
 - RATED OUTPUT: 1.00 mV/V \pm 10%
 - SAFE OVERLOAD: 150% FS
 - EXCITATION VOLTAGE: 10-20V AC/DC
 - INPUT RESISTANCE: 1080 \pm 10 OHMS
 - OUTPUT RESISTANCE: 1000 \pm 5 OHMS
 - ZERO BALANCE: \pm 1.00% FS
 - SEAL TYPE: ENVIRONMENTALLY SEALED, IP67
 - NON-LINEARITY: <0.05% FS
 - HYSTERESIS: <0.05% FS
 - REPEATABILITY: \pm 0.02% FS
 - CREEP: \pm 0.03% FS
 - COMPENSATED TEMPERATURE RANGE: -10°C - +40°C
 - TEMPERATURE EFFECT ON ZERO: \pm 0.02%FS/°C
 - TEMPERATURE EFFECT ON OUTPUT: \pm 0.001%FS/°C
 - INSULATION RESISTANCE: >5000 MEGOHMS
 - LOAD CELL CABLE: 4 CONDUCTOR, 1 FT
18. LOAD CELL WIRING:
 GREEN +EXC
 BLACK -EXC
 WHITE +SIG
 RED -SIG

RATED CAPACITY	DIMENSIONS														
	A	B	C	D	E	F	G	H	I	J	K	L	M	N	P
300KG	5.08	0.15	1.80	3.97	0.24	0.46	0.87	0.57	0.77	1.02	1.32	0.25	0.75	0.42	0.50

'DO NOT ALTER WITHOUT AGENCY NOTIFICATION'

COTI GLOBAL SENSORS, INC.

CGSS LOAD CELL

APPROVALS		DATE
DRAWN: TB	CHECKED: AB	9/16/16
ENGINEER: AB	APPROVED: AA	9/16/16
MATERIAL: STAINLESS STEEL		

THIS DOCUMENT CONTAINS PROPRIETARY INFORMATION AND SUCH INFORMATION MAY NOT BE REPRODUCED OR DISCLOSED FOR ANY PURPOSE OR USED TO PRODUCE THE ARTICLE OR SUBJECT WITHOUT WRITTEN PERMISSION FROM COTI GLOBAL SENSORS, INC.

TOLERANCES UNLESS OTHERWISE SPECIFIED
 .XX \pm 0.01
 .XXX \pm 0.005
 FRACTIONS \pm 1/16"
 ANGLES: \pm 1/2"

SCALE	SIZE	PART/DRAWING NO.	REV.
NONE	B	DOD-CGSS	-
MODEL CGSS			SHEET 1 OF 1